

SKANSKA

Health, safety, wellbeing and environment standards handbook



Contents

1	Introduction	1	9	Protecting vulnerable road users requirements	27
2	Language	2	10	Electrical safety	28
3	Supervision	2	11	Noise, dust and vibration	29
4	Culture – Injury Free Environment	3	12	Pollution prevention	30
5	Health and wellbeing	3	13	Waste	31
5.1	Health Surveillance	3	14	Energy	32
5.2	Safety Critical Worker Assessment	4	15	Water	32
5.3	On-tool extraction	5	16	Personal protective equipment	33
5.4	Face-fit testing	5	16.1	Works on the public highway	34
5.5	Drug and alcohol testing	5	16.2	Track-side specific requirements	34
6	Controls	6	16.3	Additional requirements	35
6.1	Risk assessment and safe systems of work	6	17	Asbestos	36
6.2	Task briefings	6	18	Work areas	36
6.3	Emergency arrangements	7	19	Materials	37
6.4	Permits to work	8	20	Supply chain	37
6.5	Working at height	9	21	Public interface	38
6.6	Temporary works	14	22	Communications	38
6.7	Lifting operations	15	23	Incident reporting and investigation	38
7	Excavations and buried services	22	24	Summary of items that are prohibited	39
8	Plant and equipment	24			

1 Introduction



Welcome to our health, safety, wellbeing and environment standards handbook. This is a condensed version of our full standards document. It does not replace the original document, but should be read alongside it.

All personnel are expected to follow these standards whenever working on a Skanska project. This includes trade contractors who must also show that they have appropriate health, safety, wellbeing and environment (HSWE) management systems in place and that they monitor and control their duties and tasks to be in-line with our standards.

Our HSWE requirements do not take the place of legislation, Approved Codes of Practice (ACOP) and guidance produced by the Health and Safety Executive (HSE) and other authorising bodies, but must be followed alongside them.

You will also be told about any client, project or sector-specific requirements in addition to these standards.

If there is any doubt or concern about the information provided, please consult the Skanska senior manager for your project.

This document should be read together with Skanska's sustainable procurement policy and the supplier Code of Conduct which can be found here:

<https://www.skanska.co.uk/about-skanska/supply-chain/working-with-us/>

Note: Not all sections of the original and full standards document are represented in this handbook; therefore numerical order may differ.

2 Language

Workers whose first language is not English must be able to demonstrate they have a basic understanding of both written and spoken English.

If a worker cannot demonstrate this basic understanding, their employer must:

- Translate the induction, risk assessment, method statement and briefings for them.

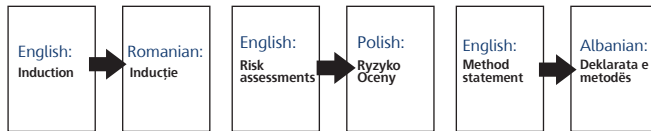

- Assign an English-speaking worker who can translate and communicate to a group of workers (maximum of four in a group).

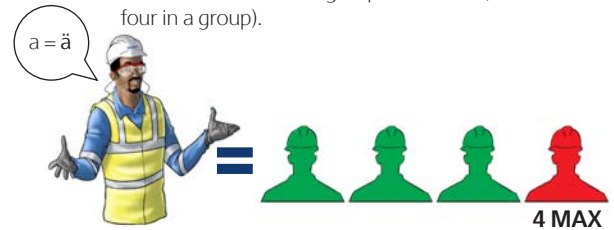

3 Supervision

Trade contractors must:

- Provide supervision for their own operatives.
- Supervise a maximum of 12 operatives in a group (when risk assessment-based and agreed with the project team).

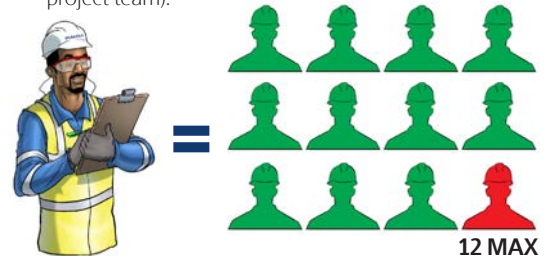

4 Culture – Injury-Free Environment

Injury-Free Environment (IFE) is about creating a culture of care and concern for each other to ensure everyone goes home safely.



Workers must attend an IFE orientation within three months of starting on site.

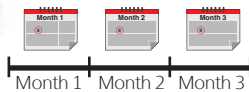

5 Health and wellbeing

5.1 Health Surveillance

Workers identified via the process of risk assessment, as being exposed to health risks in the work environment, must be included in a periodic health surveillance program.



Health surveillance is important for:



Detecting ill health effects at an early stage



Providing information to help evaluate health risks



Enabling concerns to be raised



Highlighting lapses in control measures



Providing training and education



The risk assessment should be used to identify the need for any health surveillance – the health surveillance itself must not be used as a substitute for undertaking a risk assessment and implementing effective controls.

Health surveillance can sometimes help to identify where more needs to be done to control risks. When early signs of work-related ill health are detected, action must be taken to prevent further harm and protect employees.



5.2 Safety Critical Worker Assessment

Workers defined as Safety Critical or needing Fitness for Work (FFW) medicals must be included in a periodic health assessment program.

The evidence required to prove suitability for these roles will be a copy of a 'Fitness to Work' certificate, issued by an appropriately qualified Occupational Health Provider who should be SEQOHS accredited.

Evidence of 'Fitness to Work' must be provided at induction, with the medical conducted in the month before induction. Workers must be reassessed by the Occupational Health provider if their health changes significantly, such as after:



- An injury
- Diagnosis of a condition requiring surgery



- Ongoing treatment/medication

5.3 On-tool extraction

Where it has not been possible to eliminate dust creation, on-tool extraction (OTE) equipment should be used to remove dust. Only OTE classed as medium (M) or high (H) should be used on Skanska sites – see **Skanska's dust management standard** in the full health, safety, wellbeing, and environment standards document.

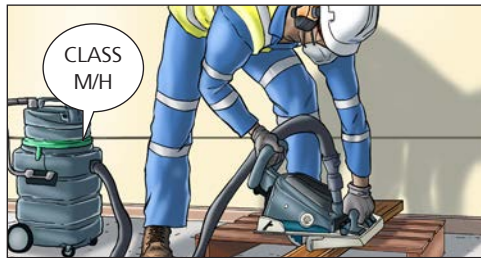

5.4 Face-fit testing

Quantitative and qualitative face-fit testing must be provided by the employer and this shall be assessed according to health and safety requirements and risk assessments to ensure legal compliance.



Workers must provide a certificate of fit testing as evidence during induction – see **Skanska's dust management standard**.

Workers must be clean-shaven and carry out daily fit checks and maintenance of respiratory protective equipment.

5.5 Drug and alcohol testing

Skanska can test for drugs and alcohol:



- Before work on site begins
- Randomly or unannounced



- After an accident has taken place or if someone is suspected of being unfit for work

Those who refuse to take a drug and alcohol test will be removed from site – see **Skanska's drugs and alcohol policy** attached to the full health, safety, wellbeing and environment standards document.

6 Controls

6.1 Risk assessment and safe systems of work

All trade contractors must provide detailed safe systems of work, including:

<p>Manual handling assessment</p>	<p>Task specific risk assessments</p>	<p>Emergency plans</p>
<p>COSHH assessment</p>	<p>Task specific method statements</p>	
<p>Health assessment</p>	<p>Noise & vibration assessment</p>	
<p>Lifting plans</p>		

All documentation must be submitted to Skanska for review and approval before any work starts. Delays will be at the trade contractor's cost.

Trade contractors must also provide evidence that all of their workers on site have been properly briefed, and keep records of attendance for review and audit purposes.

6.2 Task briefings

All supervisors must provide regular briefings to their teams:

- At the beginning of every shift - safe start briefings.



- For new activities covered by risk assessment method statements (RAMS).



- If there's a change in the work process or environment.



Supervisors, performing the briefings must:

- record it
- provide records on request



Supervisors must attend daily activity briefings (DABs) when held on the project.

Specific requirements for Facilities Services pre-task briefings will be given where appropriate.



6.3 Emergency arrangements

6.3.1 Fire prevention

Trade contractors must co-operate/comply with:

- Fire and emergency co-ordinators
- Fire wardens
- Hot works responsible persons
- Fire Precautions (Workplace) Regulations
- Fire Prevention on Construction Sites: The Joint Code of Practice

Don't:

1. Burn any materials on any project, office, depot or factory.
2. Store fuel in plastic containers.
3. Use jubilee clips for connecting gas supply hoses.
4. Use halogen lamps.
5. Smoke, unless in designated smoking areas.

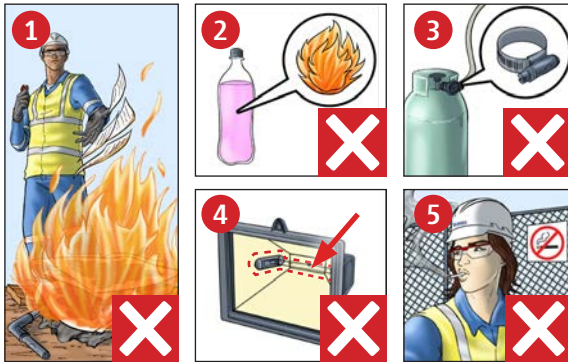

General requirements:

- The project management team must use the method statement review process to approve the storage of gas and flammable liquids inside, under and on buildings.



- A hot work permit must be enforced as per the Joint Code of Practice.



- All flexible and temporary protective coverings used on internal finished surfaces or fittings must conform to the Loss Prevention Standard (LPS) 1207 and LPS 1215.

Tar boilers must:

- Be agreed upon with the project lead.
- Have a specific risk assessment that takes into account location, operation, supervision and emergency procedures.
- Have temperature gauges and thermal cut-off mechanisms.
- Never be left unattended while lit.

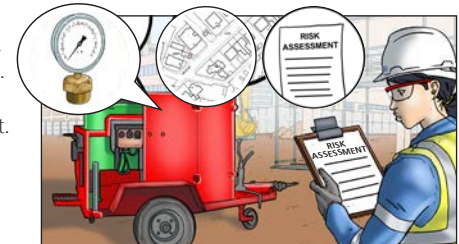

6.3.2 First aid provision

Trade contractors must provide their workforce with first aiders and supplies based on their task's or project's risk assessment.

All first aiders must hold full First Aid at Work competency.



6.3.3 Rescue plans

Trade contractors must provide:

- Suitable rescue plans when their workers will be working in locations where emergency rescue may be necessary, for example confined spaces or working at height.
- A schedule of rescue drills.
- Equipment that is regularly inspected and maintained to implement the rescue plan.



6.4 Permits to work

Permits to work:

- Are used to control high-risk activities.



- Are usually issued and controlled by Skanska or a competent trade contractor who has been appointed in writing.
- Must be completed and returned to the Skanska authorised person or permit co-ordinator.



6.5 Working at height

6.5.1 Ladders and stepladders

The following requirements must be met when using ladders:

- Only use ladders made of non-conductive materials (i.e. not aluminium ladders) when working in live electrical facilities, such as live switch rooms.
- A competent scaffolder must install and tie-off ladders (to SG25 standard) if they are needed to provide access to scaffolding or under any erection phase.
- A ladder permit system may be used on Skanska projects.
- All ladders must have a unique number (or other mark) and the contractor's name on them.
- A competent person must inspect ladders before use and once a week thereafter (keep records of this).

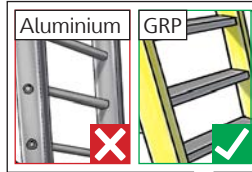

6.5.2 Mobile scaffold towers

All mobile scaffold towers must be controlled using a tagging system that shows:

- Who the tower belongs to.
- Who erected it.
- The date of the last inspection.

A PASMA-trained operative must erect and inspect mobile scaffold towers, according to the manufacturer's instructions.



Only use ladders if scaffolding, mobile towers, podiums or MEWPs are impractical.



6.5.3 Accessing the top of cabins

Do the following to avoid the need to access the top of cabins during loading and unloading operations:

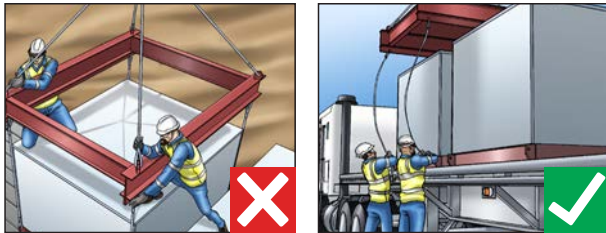

- Use low-level lifting points on cabins and ISO containers.
- Lifting points can be permanently fixed or adjustable.

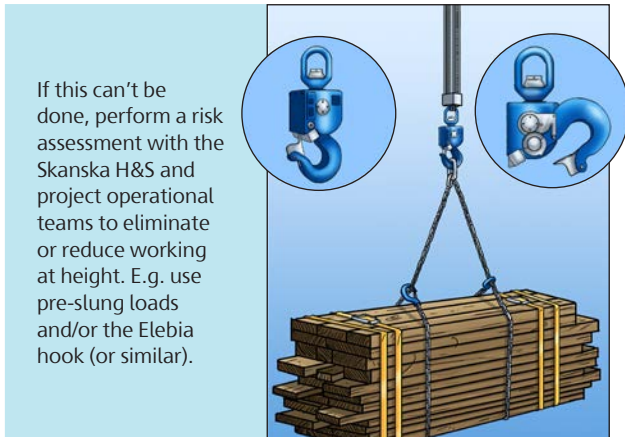

If this can't be done, perform a risk assessment with the Skanska H&S and project operational teams to eliminate or reduce working at height. E.g. use pre-slung loads and/or the Elebia hook (or similar).

6.5.4 Scaffolding

Scaffold contractors must:

- Be members of NASC.
- Employ a full-time supervisor who must possess a valid Construction Industry Scaffolders Record Scheme (CISRS) supervisor's card as a minimum.

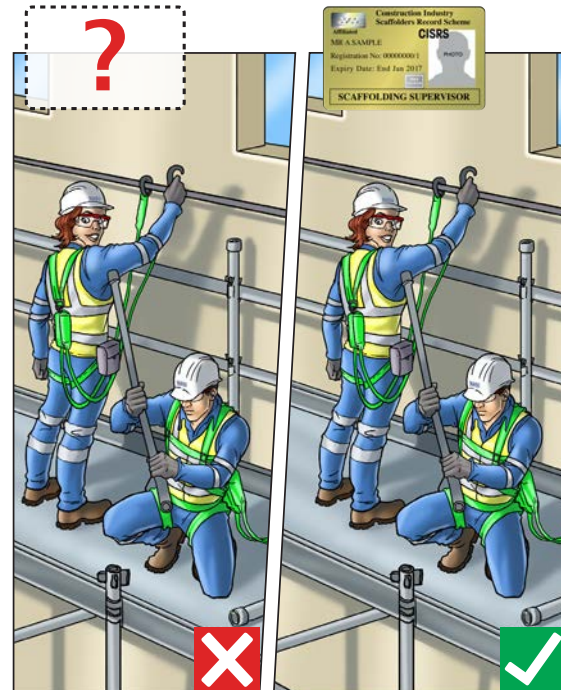

When erecting scaffolding:

- It must follow NASC TG20* guidelines wherever possible.
- A compliance sheet must be completed to show scaffolding is up to TG20 and BS EN 12811 standards.
- Staircases are the preferred access e.g. Haki/Layher.
- Ladders must only be used as access from one level to another if a staircase has been proven to be unsuitable.
- Scaffolders must follow NASC SG4 guidelines to prevent falls.

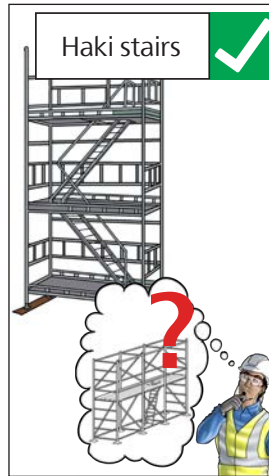
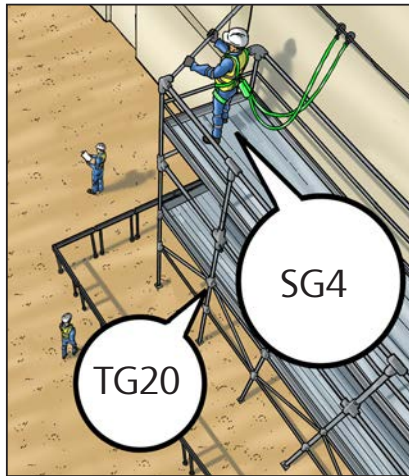

Before first use or after alterations:

- An advanced scaffolder, scaffold health and safety manager or an endorsed scaffolder with over 10 years' experience must perform an inspection.
- Scaffolds must be appropriately tagged with a Scaffoldtag.
- Findings must be recorded and given to Skanska.
- A handover certificate must be issued to Skanska.



*If non-TG20 scaffolding is needed:

- Follow Skanska's temporary works processes.
- Trade contractor must submit scaffold designs to a Skanska-approved engineer.

6.5.5 Lift shaft and riser protection

During construction, lift shafts and risers must:

- Have a working platform at every floor level below its construction.
 - working platforms must be installed from the bottom up or using another Skanska-approved method e.g. hoist internal to lift shaft.
- Have lighting at every floor level.
- Have a full-height lockable door or gate when striking the formwork or on the completion of the shaft walls at each floor level.
- Be under control of one named company.
- Have controlled access by way of a permit to work system.

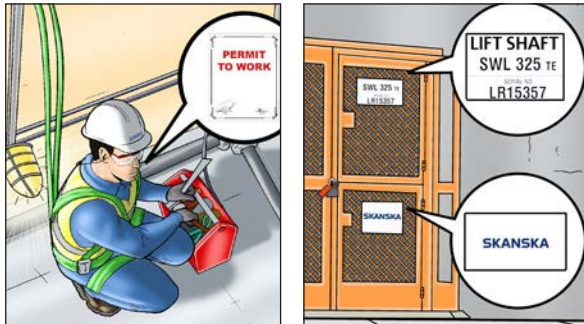

- Have signage indicating:
 - lift shaft
 - safe working load (SWL) of platforms
 - name or company of the lift shaft's controller
- Allow authorised personnel to access and reach valves and dampers.

6.5.6 Open edges and openings

To help prevent slips, trips and falls:

- If construction is steel framed, install edge protection on beams before they are lifted into place and secured.

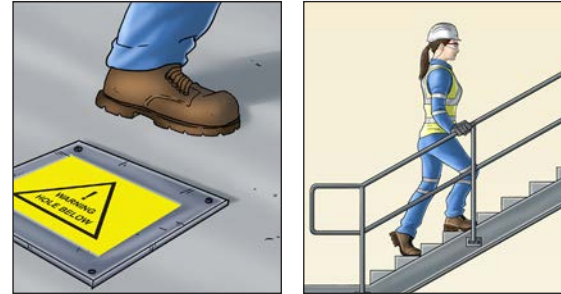

- Clearly mark openings with permanent markings.
- Staircases must have a handrail system in place.

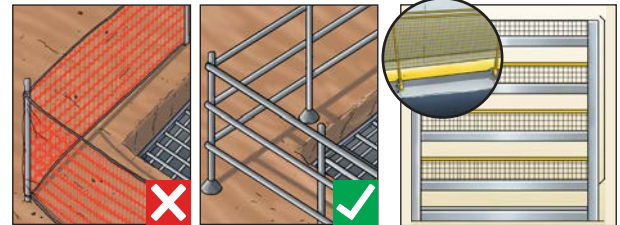

- Netlon-type fencing and barrier tapes are not allowed to be used as edge protection or as barriers for restricted areas.
- Follow the 'no gaps' standard for guard rails above the first storey. Use debris netting, K-guard or similar.

6.5.7 Falling materials and tool tethering

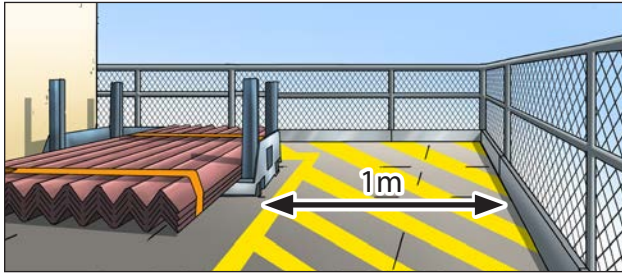

- Store all items used at height in a suitable manner to prevent them from falling.
- Perform a risk assessment for the need of clear zones adjacent to guard rails above the first storey. Clear zones should be a minimum of 1m from the guard rail and must be physically marked out.

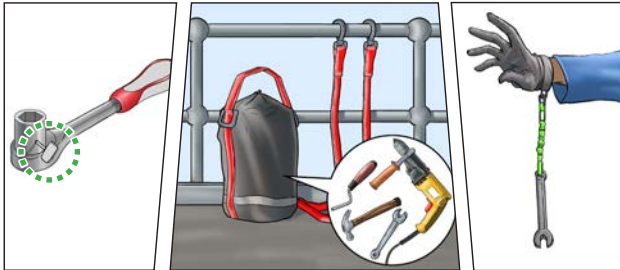

- Attach tools to tethers and suitable anchorage points if there is a risk of them falling from height.
- You must also physically secure secondary attachments. E.g. secure a socket on a ratchet with a pin.

If items can't be secured during use, create storage exclusion zones that are:

- Demarcated.
- Labelled.
- Maintained until the risk is removed.
- Suitable to contain any falling item based on an assessment (e.g. height and potential deflection).

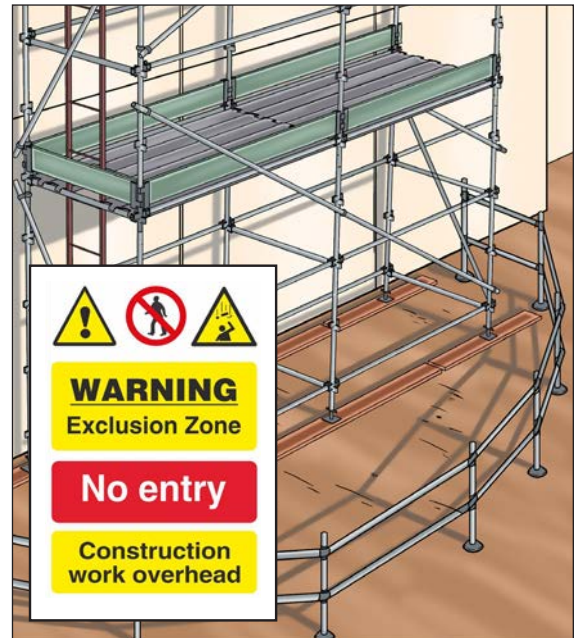

6.5.8 Mobile elevating work platforms

When working with a mobile elevated work platform (MEWP) ensure:

- A competent person who's completed the MEWP manager's course has planned the work.
- A suitable rescue plan and drill schedule is in place.
- A specific risk assessment is in place.



- There are designated, authorised and clearly identifiable users.

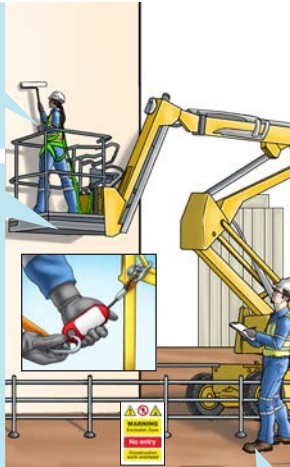

- The correct MEWP is used for the task that also complies with Skanska's MEWP policy (which requires all category 3a and 3b MEWPs to be fitted with safety devices to guard against injury from entrapment).
- Use an intelligent anchor point on all 3b MEWPs
- MEWPs are checked by Skanska before use and through daily and weekly inspections.
- MEWPs have valid certification and are removed from use if defects are identified.

- No one works alone (safety watch at all times), except for van-mounted MEWPs for short-duration tasks and after a risk assessment.

6.6 Temporary works

Please see Skanska UK's temporary works procedures in our way of working (OWOW) for information on how to minimise and control the risks throughout the temporary works life-cycle.

Responsibilities:

- The project lead must ensure a Skanska temporary works co-ordinator (TWC) is appointed.
- The TWC must ensure that all design and construction work is carried out according to the agreed temporary works procedures.
- All trade contractors must work according to Skanska UK's temporary works procedures. These procedures, and the BS5975 requirements, will be discussed at the pre-start meeting.
- All temporary works must be designed, checked, installed, dismantled and approved (in general and for loading and unloading) by competent people.



Letter of appointment

Excavations:

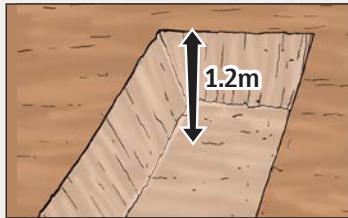

All excavations that are 1.2m deep or more must have appropriate temporary works installed. Shallowing excavations must be risk assessed to determine appropriate control measures.

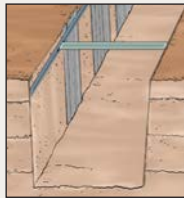

or

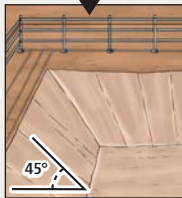

or

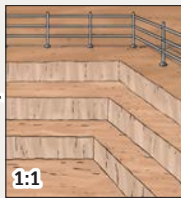

Shoring

Battering

Stepping

A competent person must perform a risk assessment to identify what appropriate engineering solution is needed (e.g. shoring, battering or stepping).



6.7 Lifting operations

Signallers must wear an orange high-visibility vest and have a CPC Slinger Signaller's card.



6.7.1 General requirements

A temporary works co-ordinator, in consultation with the appointed person, must:

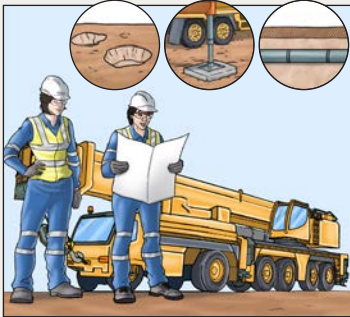

- Ensure an engineering assessment of the ground bearing capacity is done.



- Consider ground conditions, underground services and the position of any sub-structures.

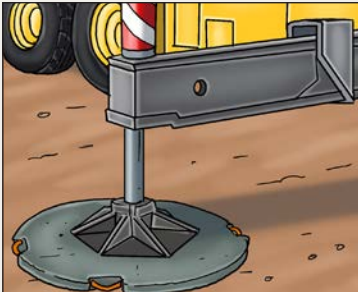

- Ensure there's a design for outrigger pads, haul roads and pavements/piling mats.

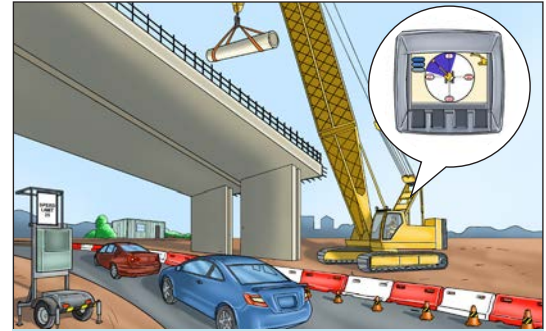
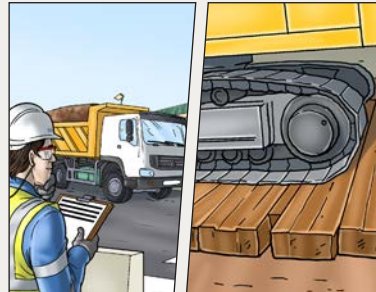

When a crane or part of the load being lifted can enter prohibited space, such as over a public highway, a site boundary or near to overhead lines, the crane must be fitted with zone limiting devices to limit both slewing and derricking.

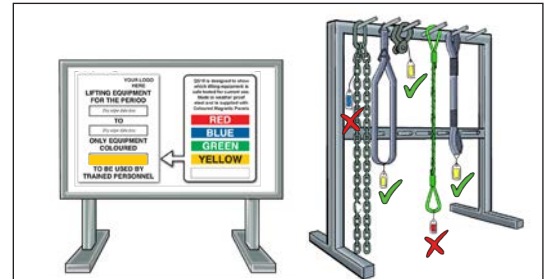

All lifting accessories must be clearly marked (colour coding or tagging system) to identify when they need to be inspected next.

Truck-mounted or small forklifts must not be used for deliveries on construction sites. Deliveries must be restricted to a suitable hard-standing segregated compound.



Where there is a risk that a tower crane or the load it is lifting could make contact with another tower crane, anti-collision devices must be fitted. Devices must be compatible with Skanska's system.



Prohibited:

- Non-hydraulic crawler cranes.
- Mobile cranes extracting sheet piles.
- Using excavators, telehandlers, lorry loads and lift trucks to lift personnel.
- Swivel hoists.
- Slings/signallers acting as crane operators (except in the case of lorry loader lifting).



- Gin wheels without automatic brakes.

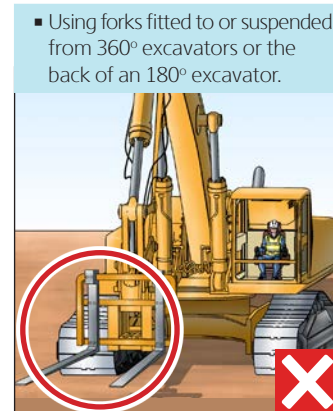

6.7.2 Lifting with excavators

Consider if an excavator is appropriate for the lifting operation and have an approved lift plan in place.

Excavators used for lifting must comply with Skanska plant standards and be fitted with:

Compatible attachments with safe working load (SWL) indicated (and included in weight of the lift).

Acoustic or visual limiter or indicator.

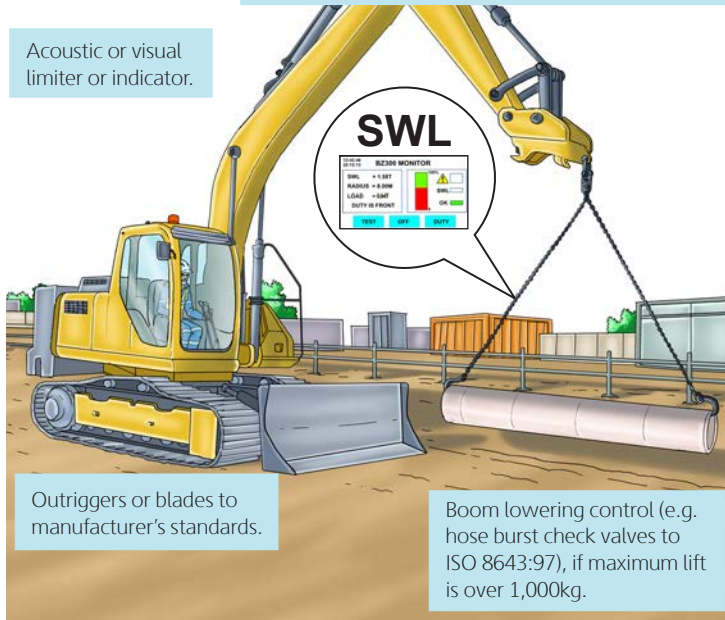

Don't rely on rated capacity indicators (RCIs) for working out the weight of a load. Calibrate RCIs at least once a year.

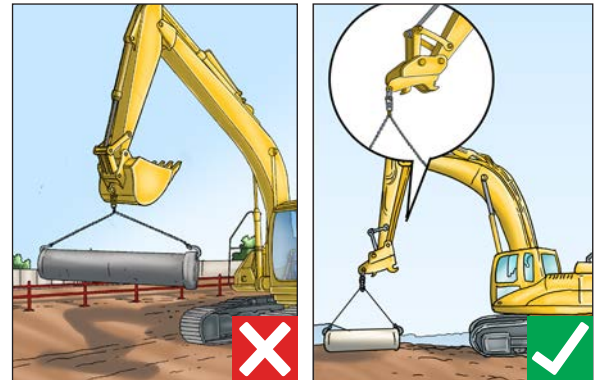

Fit excavators used in lifting operations with a load hooking device.

Before lifting:



- Remove the excavator's bucket.
- Attach the master link to the designed lifting point – ensure it's free-hanging.

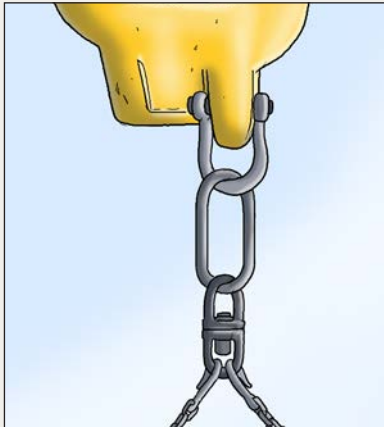

- Use a swivel shackle between the load and lifting point.

6.7.3 Loading and unloading

Follow the project loading and unloading management plan for all medium and high risk loads.

Make the following checks during unloading/loading operations:

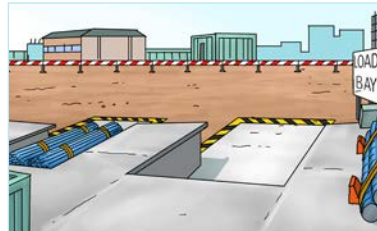

Ground/loading area:

- All unauthorised people excluded
- Ground suitable and stable
- Area free from obstructions and tidy



Equipment:

- According to the plan and correct for the load
- Inspected
- Good condition
- Includes any special personal protection e.g. anchor points and harnesses



People:

- Trained
- Authorised
- Correct number available



Vehicle:

- Suitable access
- Appropriate edge protection
- If self-unload (Hiab or Moffit forklift), check equipment and training certification

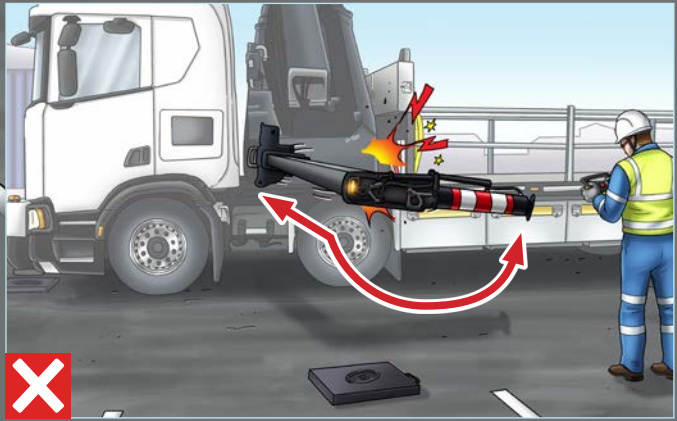
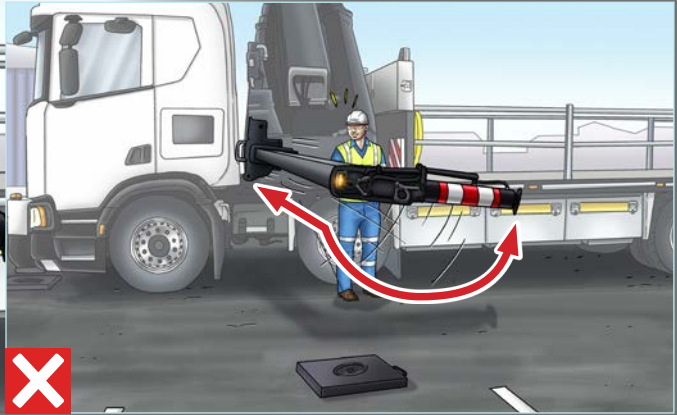

Lorry loaders fitted with hydraulic tilting and hydraulic deployment stabiliser legs that rotate across the position of the fixed controls are banned from all Skanska UK worksites. This applies regardless of their use with remote controls or any other proposed alternative means of unloading.

Consider the following when it comes to the load:



■ What is the load? Is it what is expected?



■ Where are the lifting points and are they according to the plan?



■ If pre-slung, is it according to the plan?

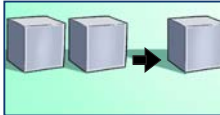

■ Did the vehicle drop off any loads previously, meaning unloading here may need re-planning?



■ Did the load shift while travelling?



■ Are the weights and the centre of gravity according to the plan?



■ Are there signs of bulging?



■ What would happen if the load is undone?

General controls:



7 Excavations and buried services

Before breaking ground:

- Skanska must issue an up-to-date permit to avoid striking underground services.



- All relevant utility plans must be on site.



- The trade contractor must provide a competent person to record the locations of underground services within the work area.



- Calibrate all equipment used for locating and recording underground services and send proof of this to Skanska when requested.

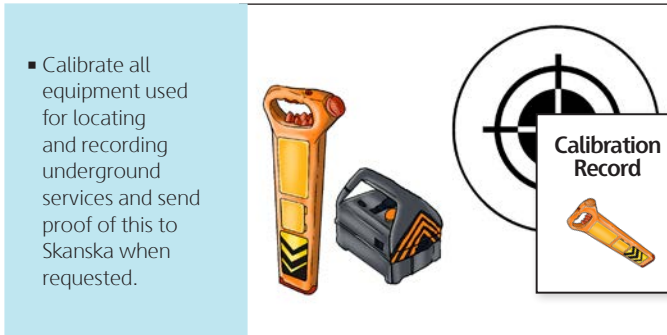



- Trade contractors must train all responsible persons who locate underground services so they are competent.



- Trade contractors who perform drilling operations through structures, e.g. core drilling, must provide the responsible person with a hand-held cable detector and manufacturer training on how to use it.

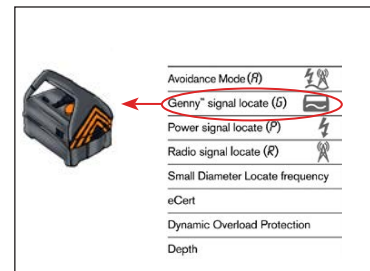

- Agree on the type of equipment to use, but ensure it provides a depth reading in genny mode and record of usage.

When breaking ground:



- Use non-contact methods for excavating where possible, e.g. vacuum excavation or air lance for excavating.



- Use electrically-insulated digging tools when digging by hand.

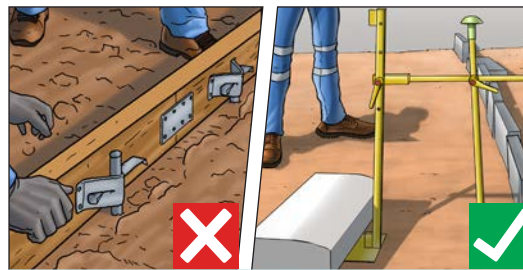

- Avoid using road pins where possible, and use alternatives like 'Pinsafe'. If this is not possible, use non-conductive road pins (fibreglass).

See **section 6.6 temporary works** for guidance on design and shoring of excavations.

8 Plant and equipment

Operators must:

- Hold a current skill card for the plant or equipment they are operating, recognised by the latest Build UK accepted record scheme.
- Get additional training if operating ancillary equipment, such as quick hitches or grabs.



Pipe coil trailers must have suitable ratchet straps and pipe end clamps. Fixed side guards for all four lower quadrants of the coil trailer and a device for dissipating the stored energy as the pipe is dispensed from the trailer.

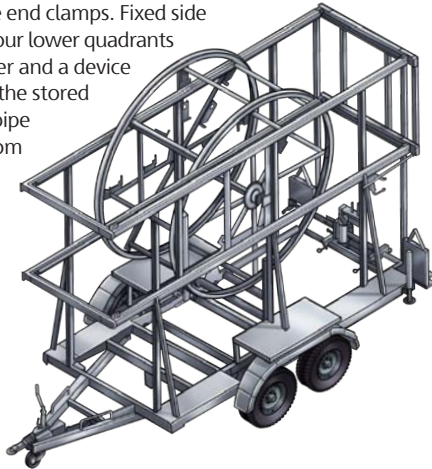

Plant and equipment requirements:



- Make all plant available for a reception check by Skanska before use.

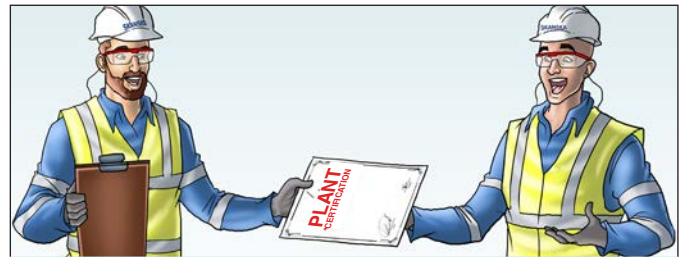

- All relevant copies of certification and documentation must be available on site if requested by Skanska.

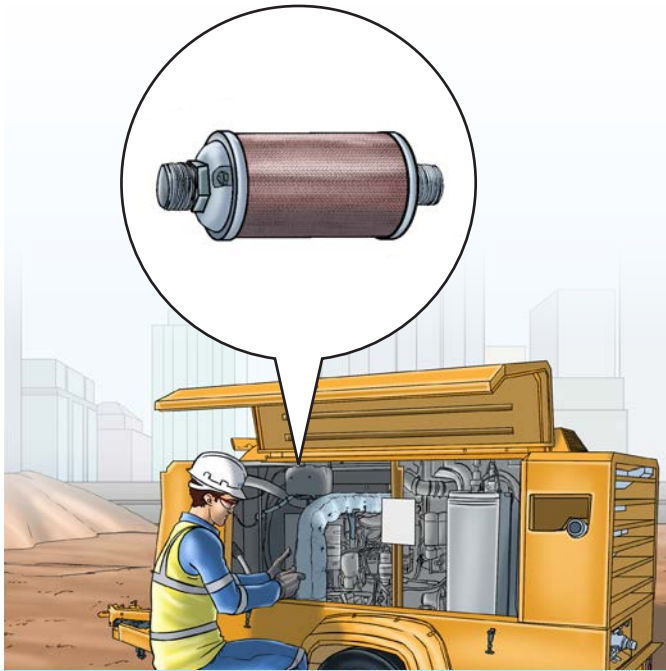

- Fit all compressors, percussion tools, plant and vehicles with effective silencers recommended by manufacturers
- Maintain all plant and equipment in good working order. Pay special attention to silencers and acoustic panels



Human-form recognition cameras must be used on all plant in scope.



Fit anti-tilt devices to wheeled dumpers of any size where the risk assessment identifies that the gradient required for operating may pose a risk of overturning.

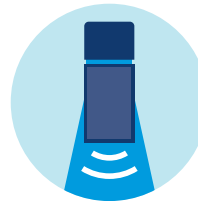

Surround-view visibility: fit all plant with blind spots with a proximity warning system which meets the technical requirements for all-round visibility.

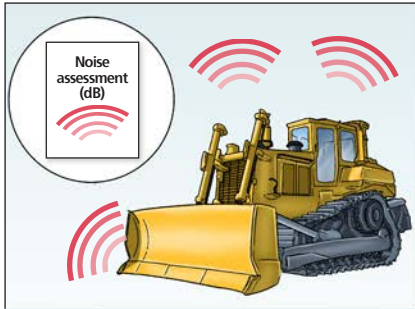

- Provide plant sound power levels in decibels (dB). All plant must comply with permissible noise levels as per the European Directives and any local restrictions.

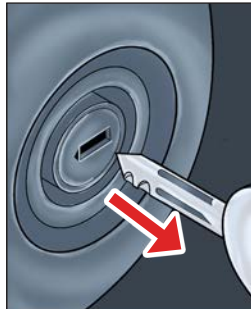

- When not in use, shut down or reduce plant to idling speed.



- All items of plant with blind spots (within the scope of the Skanska standard), must be fitted with a proximity warning system that meets the requirements for surround view visibility.



- All equipment and plant must comply with air emission guidelines, for example, London Low Emission Zone.

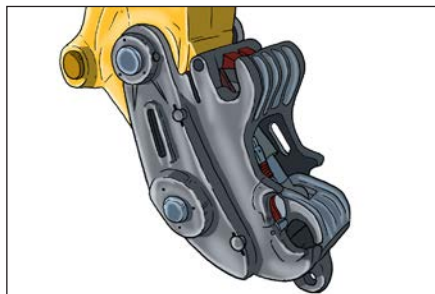

- Use 'new generation' quick hitches that have a fully automatic double-locking device that locks both pins of the bucket.

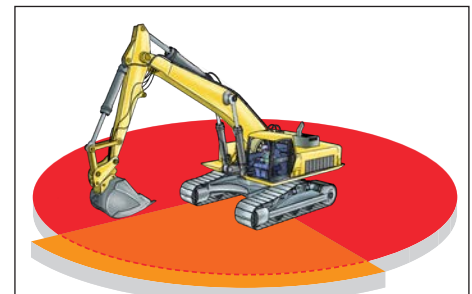

- Implement and maintain exclusion zones when using excavators and other mobile plant.

Note: Trade contractors must ensure horizontal directional drilling rigs have safety guards that comply with HSE requirements to prevent entanglement.

- One-tonne dumpers must not be used due to risk of overturning.

Forward-tipping dumpers above six tonnes must have the following features to ensure operators have clear visibility:



- Raised driver seat.

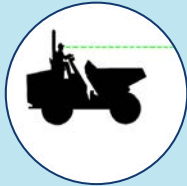

- An angled skip to maintain visibility.



- Low head board.



- Use auto-retractable safety knives. If not practical, use a fixed Stanley blade after a risk assessment and control measures have been agreed with the Skanska project team.



- Using metal tri-blades or chain-link blades on brush cutters and trimmers are prohibited.

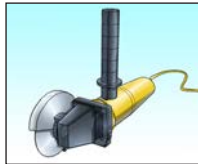

- Only use angle grinders with their correct guarding in place and if you have an abrasive wheels training certificate. NOTE: petrol-driven cut off saws require a separate qualification.

9 Protecting vulnerable road users requirements

All parties who bring vehicles on site must comply with Skanska protecting vulnerable road users policy and:

- Sign-up to the CLOCS 'Memorandum of Understanding'.
- As a minimum, have silver FORS status.
- Work towards gold FORS status.



10 Electrical safety

All electrical portable appliances must be:

- Portable Appliance Tested (PAT).
- Recorded on a register.
- Labelled with:
 - trade contractor's name
 - plant hirer's name
 - next test due date

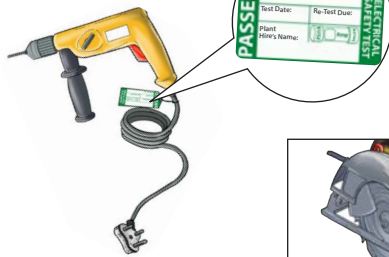

Multiway plug and socket adaptors must be fused and surge protected.

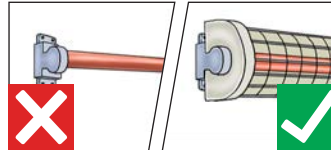

Radiant space heaters, tubular heaters without wire cages and heaters without thermal overloads are not allowed on site.



Only use 240V chargers if they are approved by a project lead and in designated and agreed locations.

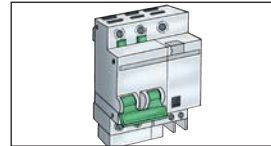

Type of equipment	110V	230V	Fixed RCD's	Equipment in site offices
User checks	Weekly, recorded	Daily/every shift	Daily/every shift	Monthly
Formal visual inspection	Monthly	Weekly	Weekly	Monthly
Combined inspection and test	Before first use, then every 3 months	Before first use, then once a month	Before first use, then every 3 months (portable RCD's, once a month)	Before first use, then yearly

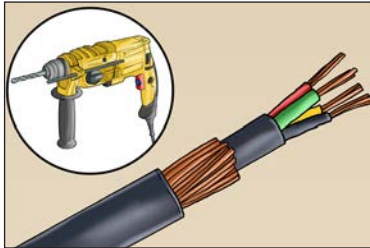

Portable and hand-held tools that use more than 110V can only be used if there's no alternative and:

- They are centre tapped to earth.
- They have armoured cable.
- Additional RCD's are fitted.

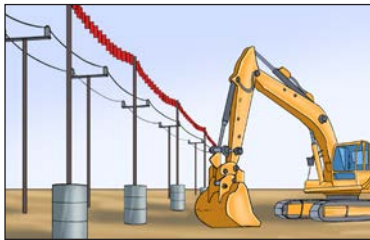

Before starting work near overhead power cables:

- The Skanska project lead must give approval.
- Take all precautions and protection, as per HSE guidance note GS6 "avoiding danger from overhead power lines".

11 Noise, dust and vibration



Trade contractors must manage and reduce noise, dust and vibration caused by their activities which include:

- Complying with **Skanska's dust management standard**.
- Providing risk assessments and method statements for agreement with Skanska.



- Using rain or grey water to dampen down dust where possible.

12 Pollution prevention

To help prevent and contain pollution:

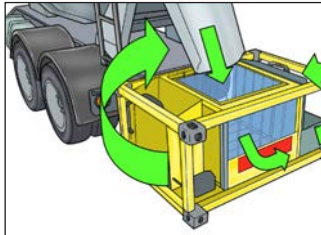

- Follow regulatory guidelines to prevent pollution when washing out concrete, e.g. use a proprietary concrete wash water treatment system.



- Ensure mobile fuel bowers and compressors have the correct size drip tray (e.g. Plant Nappies) underneath them at all times.
- Empty drip trays/plant nappies of rainwater without causing pollution e.g. pump clean water from the bottom of the tray.

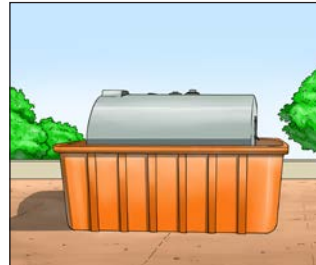

- Place static fuel tanks on an interceptor drip tray, even if they're double-skinned or bunded.



- The appropriate type and quantity of spill kits must be available.

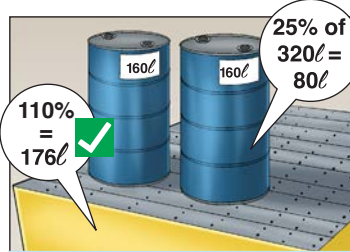

- Bund fuel drums or CoSHH substances to 110% capacity of the largest container, or 25% of all containers – whichever is greatest.

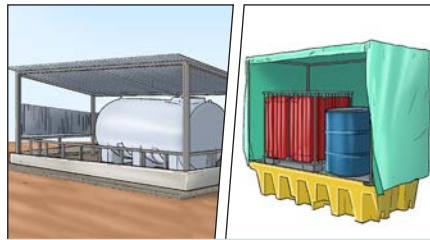

- The bund can either be a plastic sump pallet or a concrete built-in-situ.
- The bund must also be covered to prevent water from entering it.

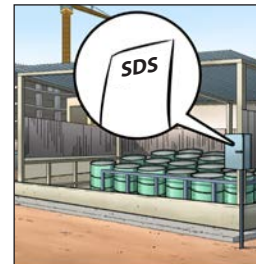

- Display safety data sheets (SDS) next to bunds.



- Store smaller CoSHH items in site safes with the relevant SDS. Store mastics and aerosols separately.

13 Waste

Skanska has a commitment to delivering zero waste to landfill and have a long-term objective to generate zero waste from its projects.

Follow the waste hierarchy and waste duty of care requirements, as well as take all reasonable steps to:

1. Prevent unauthorised or harmful deposit, treatment or disposal of waste.
2. Prevent others from not following the requirement of an environmental permit or permit condition.
3. Prevent waste escaping from your control.
4. Ensure whoever you transfer waste to has the correct authorisation and an accurate description of the waste.



Trade contractors responsible for their own waste must provide the following before waste (including hazardous waste) leaves a Skanska site:

- A site waste management plan.
- A waste classification undertaken in accordance with the regulatory guidelines.
- Waste carriers registration, as issued by the Environment regulator.
- Environmental permits for all facilities where waste is transported to.

- Place waste into separate skips (concrete and hardcore, wood, plasterboard and metal).
- Place hazardous waste (e.g. used CoSHH items, contaminated spill kit materials) in lockable wheelie bins.
- Display signage on every skip and container to identify the correct waste type.
- Return all timber pallets to suppliers.
- Supply monthly waste data to Skanska using the Skanska template.

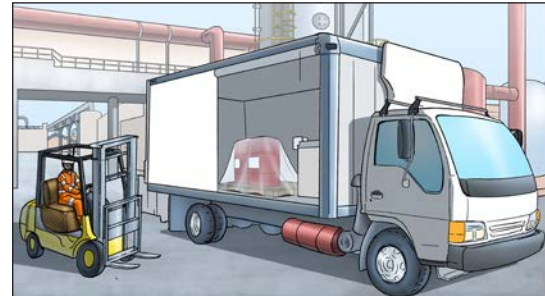

- Use a specialist company to source suitable containers (e.g. clip-top drums) for hazardous waste and removal from site.

14 Energy

Skanska's long-term objective is to minimise energy use and embodied energy contained in its products.



Trade contractors must therefore:

- Report all energy use (e.g. electricity, site diesel) and embodied energy in materials (for carbon footprinting calculations) to Skanska on a monthly basis, using the agreed format.
- Include details of how associated emissions and embodied energy during material production have been minimised.

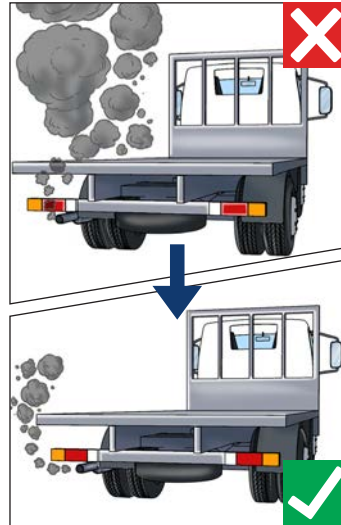

15 Water

Skanska's long-term objective is to minimise water use and embodied water contained in its products.



Trade contractors must therefore:

- Report all potable water use and embodied water in materials to Skanska on a monthly basis, using the agreed format.
- Include details of how associated water use and embodied water have been minimised.



16 Personal protective equipment

As a minimum standard of personal protective equipment (PPE), the following must be provided and worn at all times:



- Appropriate-coloured safety helmet (or bump cap if adequate).
- Chinstrap or other restraining device for safety helmet, if applicable through a risk assessment.



- Safety glasses that incorporate prescription lenses and impact rated, where necessary.
- Safety visors used for brush cutting must be either: impact rated polycarbonate (EN166 1B), or, metal mesh visor with impact rated safety glasses (EN166 1B) underneath.



- Task-specific gloves.



- High-visibility jacket or vest (Class 2, or Class 3 when required by a project-specific risk assessment).



- Safety footwear with toe and mid-sole protection and ankle support.

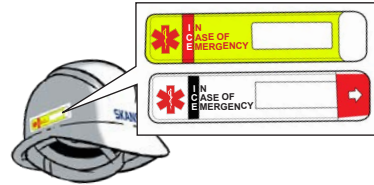

Head protection must display a completed 'in case of emergency' tag and the wearer's name (first name, full name or nickname if non-offensive).

All personnel must cover their torso and legs at all times. Arms must be covered when required by a risk assessment.

Wear all-in-one protective clothing for heat and flame (FR Index 3 and Arc Class 1 as standard) when breaking ground and there's a risk of coming into contact with live services.



All projects starting from January 2017 must use the following safety helmet colours:

	Black: Supervisor		White: Management and competent operatives and trades
	Orange: Slinger/signaller		Yellow: For identifying management from competent workforce (this is optional and will be communicated locally)
	Blue: Visitor/young person/ inexperienced worker		

16.1 Works on the public highway

Wear:

- High-visibility jacket or vest (Class 3).
- High-visibility trousers for high speed roads or when required by a risk assessment.



16.2 Track-side specific requirements

Safety helmets:



Wear white safety helmets on or near the line side.



Wear blue safety helmets if you:

- Have a Track Visitor's Permit (TVP).
- Are in receipt of a Personal Track Safety (PTS) card with a green square on it.
- Are included in the Infrastructure Maintenance New Starters Mentoring (Passport) Scheme (provision NR/PRC/MTC/SE0089).

Names or logos of the worker's Sentinel sponsor (or other logo agreed with Network Rail) can appear on safety helmets as long as it doesn't exceed more than 10% of the helmet's visible surface.

Safety footwear for trackside:

Safety footwear must:

- Comply with BS EN SIO 20345.

Provide ankle support (lace up, NOT rigger type).

Have a covered protective toecap.

Have mid-sole protection.



Visibility clothing:

High-visibility orange body clothing with reflective tape must:

- Comply with Railway Group Standard GO/RT 3279 and BS EN 471 Class 2. This includes:



- Be clearly marked on the back with the relevant Sentinel sponsor's logo or other logo as agreed with Network Rail.
- Be supplied by the Sentinel sponsor, if their logo is on it.
- Not include other logos, unless approved by the Network Rail project manager.

In addition:

- Logos must be directly printed on the back of the material, between the vertical retro-reflective bands.
- High-visibility trousers must comply with Railway Group Standard GO/RT 3279 and BS EN 471 Class 1.
- Foul weather clothing (jacket and trousers) must comply with Railway Group Standard GO/RT 3279 and BS EN 471 Class 3 (Gortex type breathable/water-resistant material).

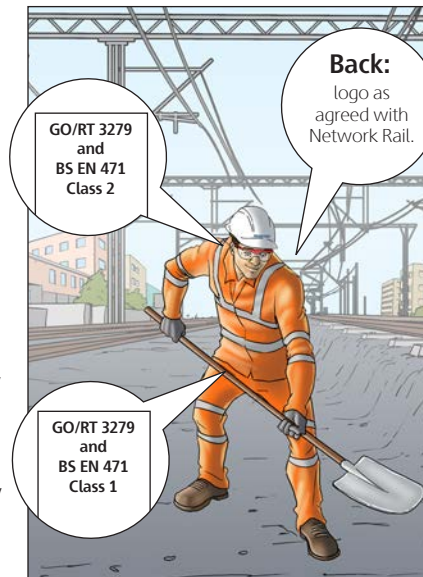

16.3 Additional requirements

Additional PPE, as per a task-specific risk/ CoSHH assessment, may be required.

The minimum standard for disposable face masks is FFP3. All users of filtering face pieces RPE must be face-fitted/tested for each specific RPE worn.



Trade contractors must return all PPE, if supplied by Skanska. Any items not returned will be charged a levy.

17 Asbestos

Skanska will advise trade contractors if asbestos is present on a project.

Only specialist contractors, approved and licensed by the HSE, may work with asbestos.



18 Work areas

Store all materials on pallets, racks or specialised storage systems.

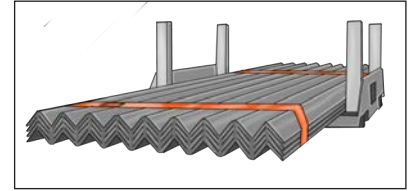
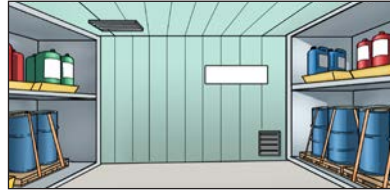

Secure temporary electric cables (junction boxes, extension leads, etc.) with "sky hooks" or equivalent, and route them safely so they don't cause tripping hazards.

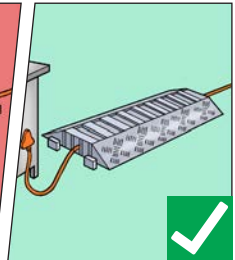
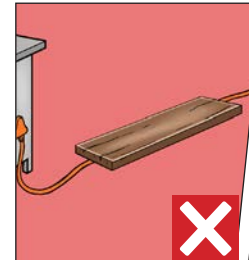
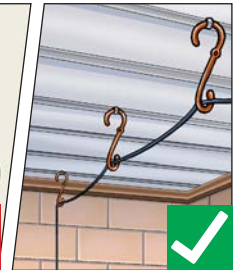
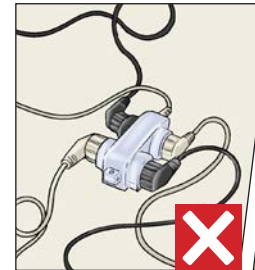
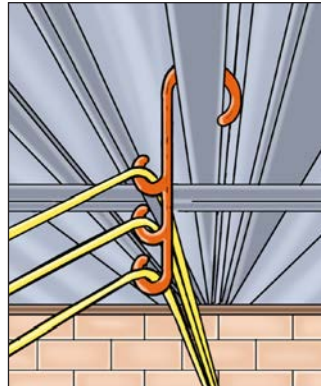

19 Materials

Skanska's objective is to only use sustainable materials that are also non-harmful to humans and the environment. Details at: <https://www.skanska.co.uk/about-skanska/supply-chain/working-with-us/>

Trade contractors must:



- Report all timber and timber product deliveries.



- Report all quarried product deliveries.



- Record all products that contain recycled material.

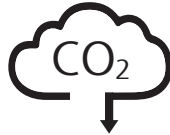

- Report all delivery mileage, vehicle type and associated CO₂ emissions, as well as details of how CO₂ emissions have been minimised.



- Provide supporting delivery notes on request, and clearly show the chain of custody number for timber deliveries.
- All reports must be made available to Skanska on a monthly basis and in the agreed-to format.

20 Supply chain



- All trade contractors must be assessed and approved for Safety, Health, Environmental and Quality competency before any works start.
- Safety advisors nominated by trade contractors must meet competency requirements (minimum NEBOSH General or Construction).

21 Public interface

Trade contractors must conform to project-specific requirements for maintaining the site boundary's integrity. All barriers must be erected according to manufacturers' instructions or follow temporary works design.



22 Communications

Trade contractor representatives and operatives are expected to participate and support Skanska regular communication events on all projects. This includes, but is not limited to:

- Toolbox talks
- IFE stand ups
- Global Safety Stand Downs
- Health and safety alert briefings
- Pre-task briefings

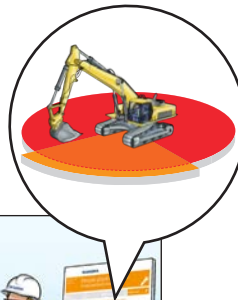

23 Incident reporting and investigation

- Report any and all incidents to help us improve everyone's safety on site.
- All incidents and near misses must be reported to the Skanska project manager immediately and recorded.

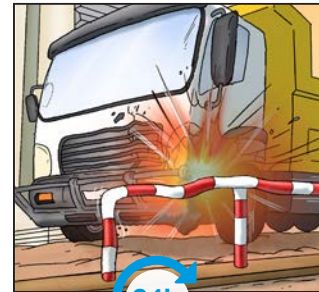

24 Summary of items that are prohibited



- Fuels stored in plastic containers.

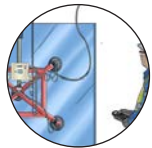

- Radio-controlled glass lifting accessories.

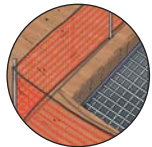

- Netlon-type fencing as edge protection or as a barrier for restricted areas.



- Forks fitted to or suspended from 360°/180° excavators.



- Truck-mounted or small forklifts in construction areas; unless on hard standing ground in a segregated area.



- Halogen lamps.



- Underslung loads from wheeled plant whilst in motion.



- Barrier tape as edge protection or as a barrier for restricted areas.



- Vehicles only certified to FORS Bronze or with no certification.

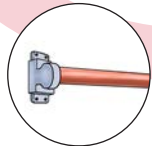

- Tubular space heaters without cages.



- Aluminium ladders or stepladders in live electrical areas.

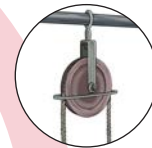

- Gin wheels without brakes.



- Lifting with excavators without removing the bucket.



- One-tonne dumpers.



- Road pins, including non-conductive road pins, are not permitted to be used, except where the presence of underground services can be eliminated beyond all reasonable doubt.

SKANSKA

Skanska UK
www.skanska.co.uk

1 Hercules Way
Leavesden
Watford
WD25 7GS